

# Fechadura Móveis em Aço F4040CR

# hardt

## Componente

Item	Componente	Quant.
1	Tambor 19x20mm	02
2	Anel travamento	01
3	Porca sextavada estriada	01
4	Lingueta	01
5	Parafuso métrico estriado	01
6	Chave	01

## Dados do Produto

Acabamento	Cromado
------------	---------

## Dimensões do sistema

### Tambor

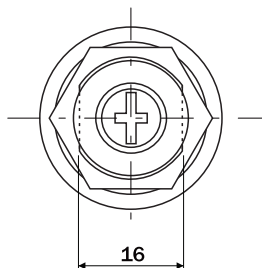
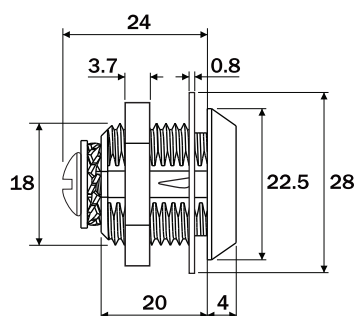

### Lingueta

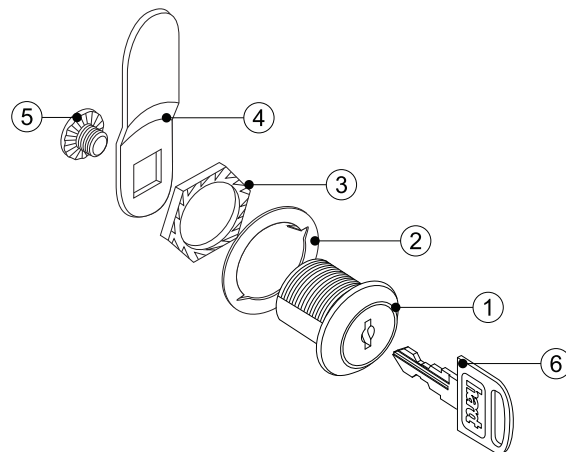
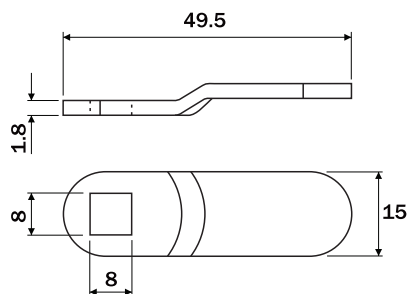

### Furação

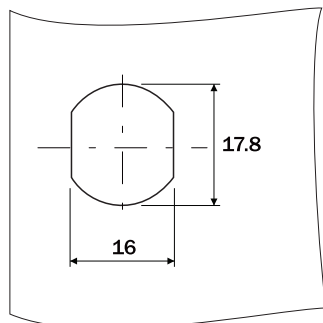

### Abertura / Fechamento

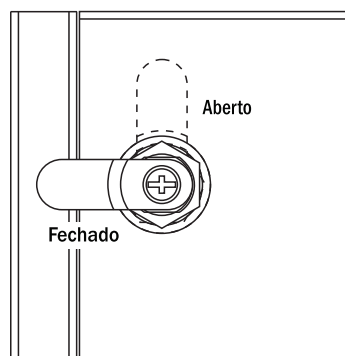

## Montagem

