

Gaveta Metal H133

hardt

Dados do Produto

Código	Comp.P	Comp.P1
S0218CZ	450	455
S0220CZ	500	505
Abertura	Extração Total	
Altura da Gaveta	133.5	
Capacidade de Carga referencial	máx. 35Kg	
Acabamento	Cinza	

Componente

Item	Componente	Quant.
1	Corrediças Embutidas	02
2	Laterais H133	02
3	Conectores Frontais + Parafusos	02
4	Capa Acabamento Lateral	02
5	Parafusos AACP4X16	20

Furação da Corrediça

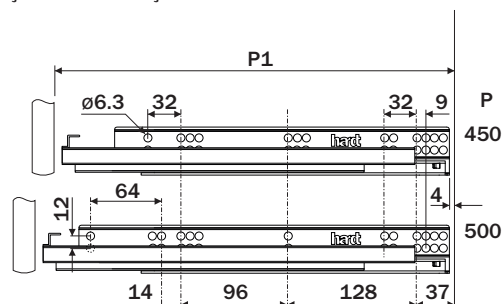

Vista frontal

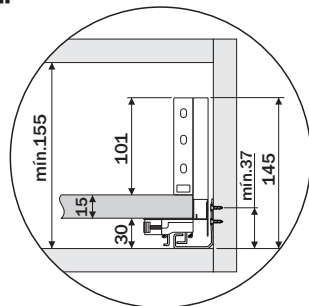

Espaço mínimo necessário

Dimensões para o corte dos painéis (15mm)

L= Largura interna do móvel
P= Comprimento da corrediça

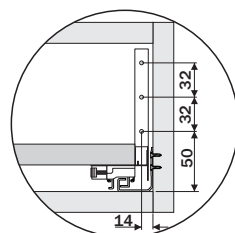
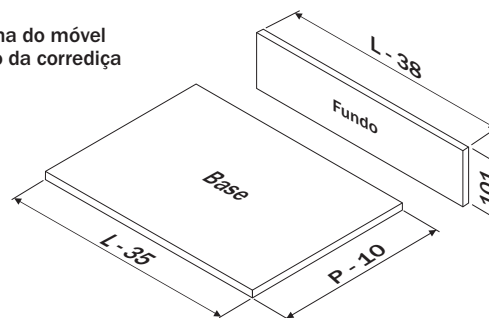

Fixação conectores frontais

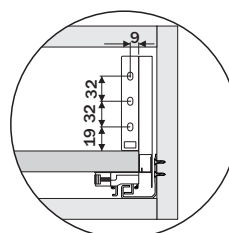

Fixação fundo

Montagem da Gaveta

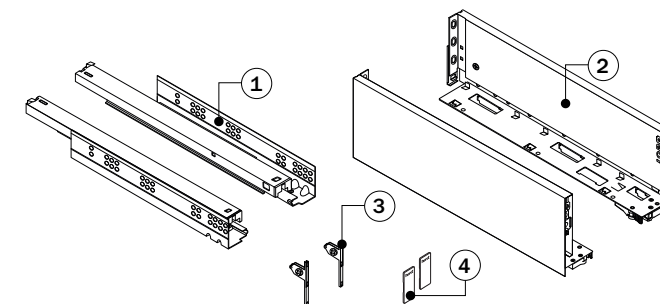
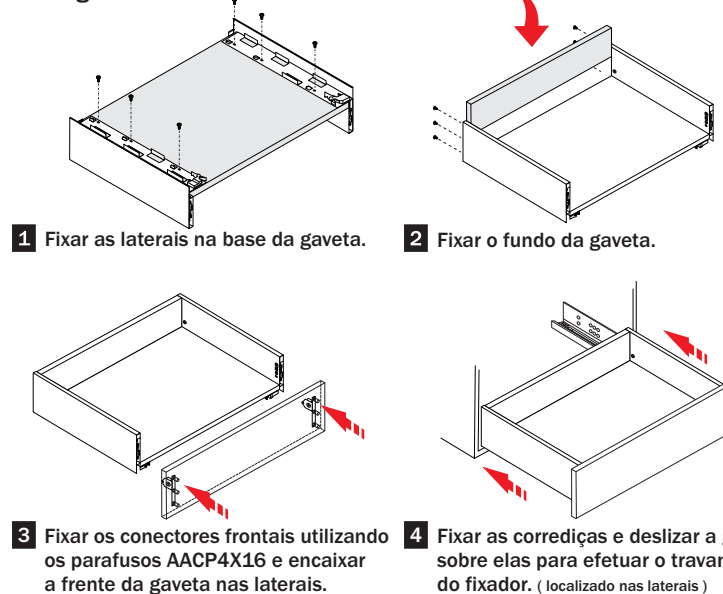

Ajustes 3D

Regulagem profundidade (corrediça)

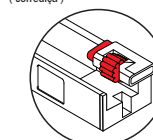

Regulagem inclinação

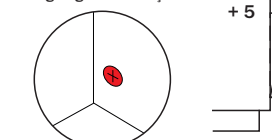

Regulagem vertical

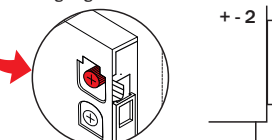

Acabamento

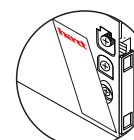

Após a regulagem, encaixe as capas de acabamento.

Regulagem horizontal

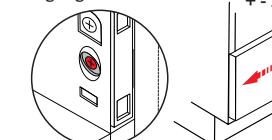

Desmontagem da Gaveta

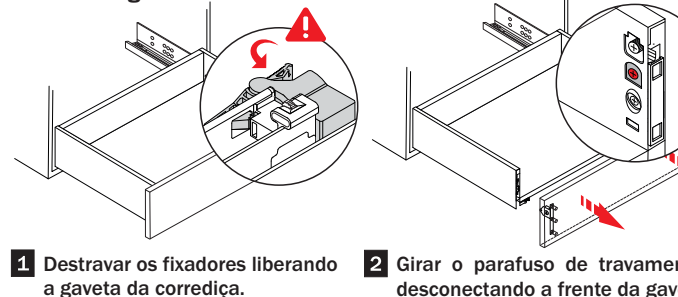

Gaveta Metal H133 Interna

hardt

Dados do Produto

Código	Comp.P	Comp.P1
S0218CZ	450	455
S0220CZ	500	505
Abertura	Extração Total	
Altura da Gaveta	133.5	
Capacidade de Carga referencial	máx. 35Kg	
Acabamento	Cinza	

Gaveta H133 Interna

Item	Código	Componente	Quant.
1	S0201CZ	Conectores Frontais + Parafusos	02
2	S0202CZ	Painel frontal 1m	01
3	S0203CZ	Perfil frontal 1m	01
4	S0103ZN	Acessórios Montagem Gaveta Interna 4X Parafuso AACP4X16 1X Parafuso AACC4X16 1X Fixador frontal	01

Furação da Corrediça

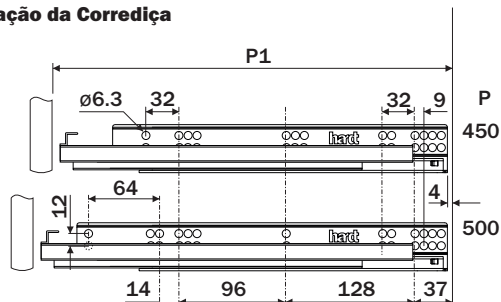

Montagem da Gaveta

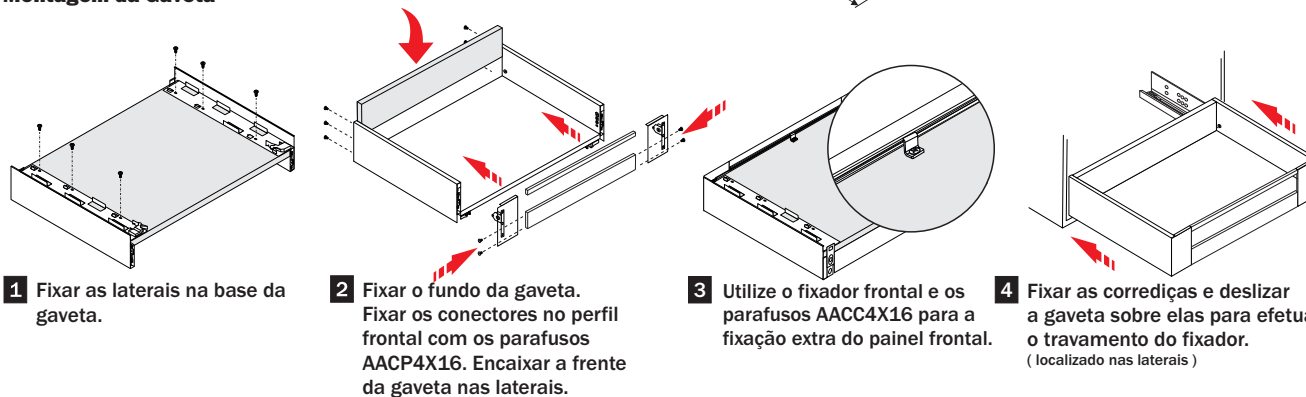

1 Fixar as laterais na base da gaveta.

2 Fixar o fundo da gaveta. Fixar os conectores no perfil frontal com os parafusos AACP4X16. Encaixar a frente da gaveta nas laterais.

3 Utilize o fixador frontal e os parafusos AACP4X16 para a fixação extra do painel frontal.

4 Fixar as corrediças e deslizar a gaveta sobre elas para efetuar o travamento do fixador. (localizado nas laterais)

Dimensões para o corte dos painéis (15mm)

L= Largura interna do móvel
P= Comprimento da corrediça

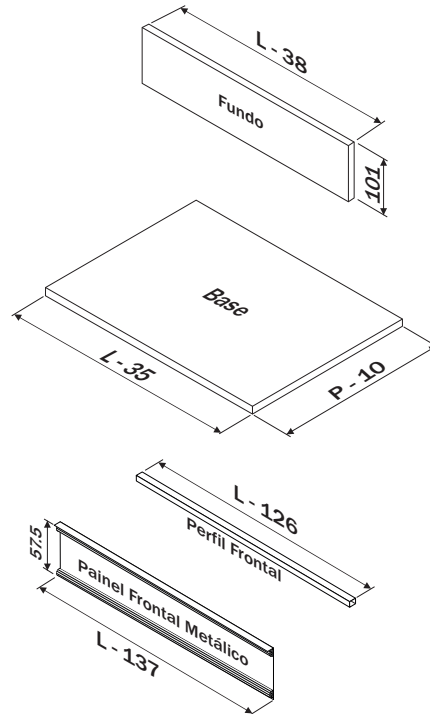

Vista frontal

Espaço mínimo necessário

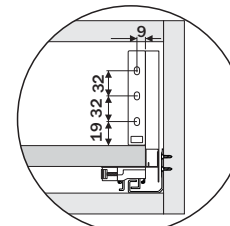
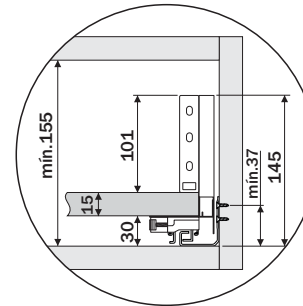

Fixação fundo

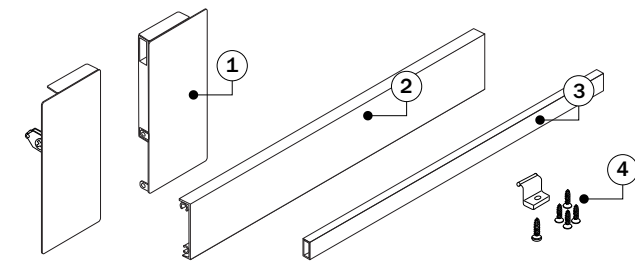

Ajustes

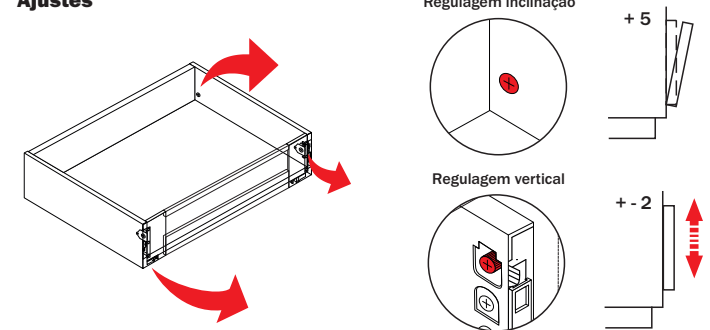

Acabamento

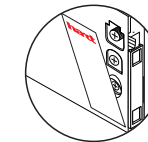

Após a regulagem, encaixe as capas de acabamento.



Desmontagem da Gaveta

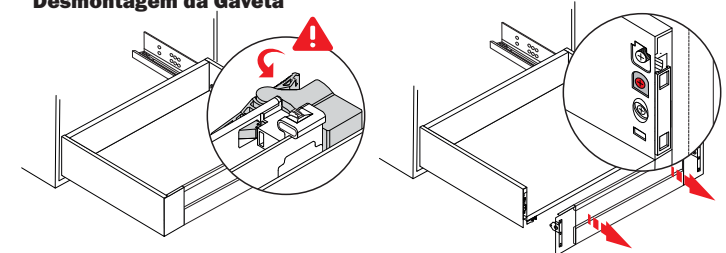

1 Destruar os fixadores liberando a gaveta da corrediça.

2 Girar o parafuso de travamento desconectando a frente da gaveta.